

May 30, 1967

J. F. KING, JR

3,322,374

MAGNETOHYDRODYNAMIC PROPULSION APPARATUS

Filed Sept. 30, 1964

2 Sheets-Sheet 1

Fig-1

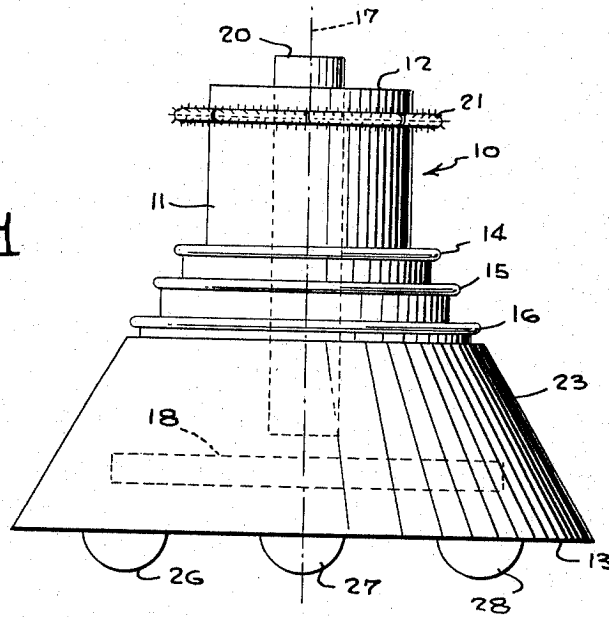
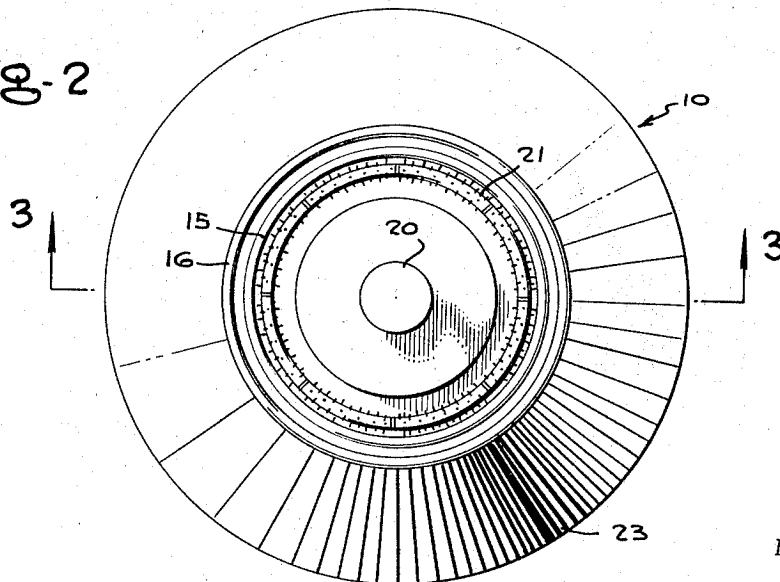

Fig-2



INVENTOR

JAMES F. KING, JR.

BY  
Mason, Fenwick & Lawrence  
ATTORNEYS

May 30, 1967

J. F. KING, JR

3,322,374

MAGNETOHYDRODYNAMIC PROPULSION APPARATUS

Filed Sept. 30, 1964

2 Sheets-Sheet 2

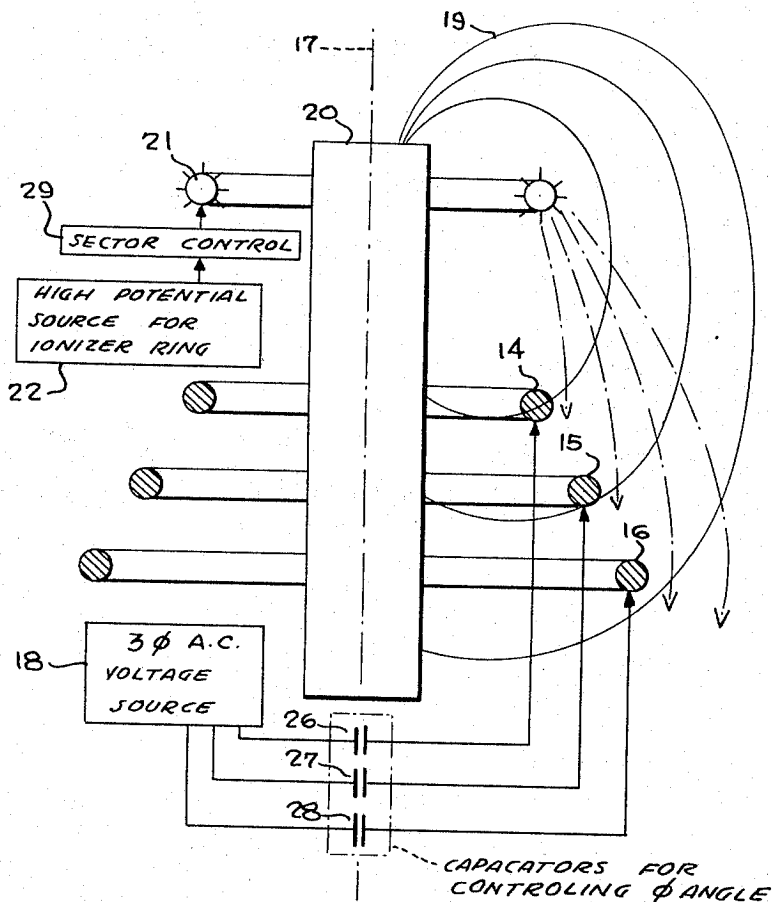

Fig-3

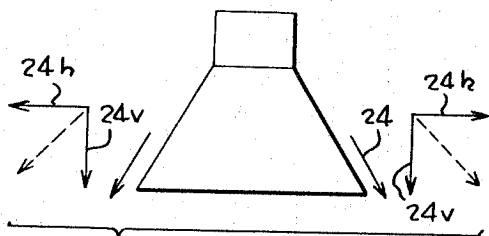

Fig-4a

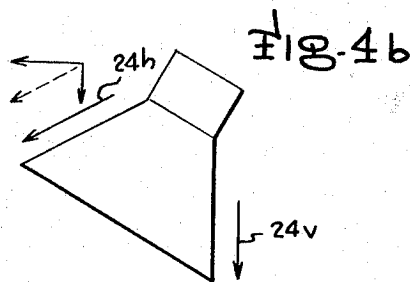

Fig-4b

INVENTOR

JAMES F. KING, JR.

BY Mason, Fenwick & Lawrence ATTORNEYS

3,322,374  
**MAGNETOHYDRODYNAMIC PROPULSION  
 APPARATUS**

James F. King, Jr., 925 Goodwood Road,  
 Winston-Salem, N.C. 27106  
 Filed Sept. 30, 1964, Ser. No. 400,456  
 9 Claims. (Cl. 244-62)

The present invention relates in general to craft propelled by magnetohydrodynamic effects and methods of propulsion and control thereof, and more particularly to heavier-than-air craft which are propelled by interaction of magnetic fields upon electrically conductive fluids such as plasma, surrounding the craft.

The technological field of magnetohydrodynamics, frequently referred to as MHD, is concerned with the study of dynamic effects of magnetic fields upon electrically conducting fluids, a prime example of which is plasma. The term "plasma," has been variously defined as a space charge neutralized ion cloud containing substantially equal numbers of positive ions and negative electrons, or any mixture of particles, some of which are charged, whose spatial dimension exceeds the Debye length and where the percentage of the mixture that is ionized contains an approximately equal number of positive and negative particles so that the overall aggregate is electrically neutral. As used in the present discussion, the term "plasma" is intended to describe a gas or electrolyte which in addition to meeting the criteria just given is in such a state of ionization that it becomes conductive enough to be affected by magnetic fields. That is to say, such an electrically conductive fluid medium containing charged particles is sufficiently conductive so that electric currents in the nature of eddy currents may be induced in the fluid medium by magnetic fields by the phenomena known as "mutual induction."

An object of the present invention is the provision of a novel method and apparatus for propulsion of craft which relies upon interaction of magnetic fields produced by electrical currents in conductors on the craft with a surrounding electrically conductive environment or medium to produce reaction thrust.

Another object of the present invention is the provision of a novel propulsion method and apparatus for heavier-than-air craft surrounded by a plasma or ionized field produced by the craft.

Another object of the present invention is the provision of a heavier-than-air craft having self-contained means for generating an ionized or plasma field in air surrounding the craft and means for generating a polyphase excited moving magnetic field of such character that currents are induced in the surrounding ionized or plasma field which constitutes a mobile fluid conductor and the conductor medium is propelled by the moving magnetic fields to produce reactive thrust for propelling the craft.

Yet another object of the present invention is the provision of propulsion apparatus for a craft of the character described in the preceding paragraph arranged in such a way as to permit direction control and impart inherent stability to the craft similar to that attained with dihedral wing arrangements.

Other objects, advantages and capabilities of the invention will become apparent from the ensuing detailed description and accompanying drawings.

Heretofore, arrangements have been disclosed for propulsion of craft by establishing high electrical D.C. potentials between spaced conductors or electrodes and thereby generating ions or charged particles which are electrically attracted in a selected direction and through collision with air molecules create a propulsive force.

Examples of such arrangements may be found in U.S. Patent No. 3,120,363 to Hagan and U.S. Patents No. 2,949,550, No. 3,018,394 and No. 3,022,430 to T. T. Brown. These devices, however, rely on the generation and migration of ions by means of the high D.C. potentials between the spaced electrodes providing an action force at least predominantly in a selected direction and a consequent reaction force on the device in the opposite direction pursuant to Newton's third law of motion.

Another arrangement which was proposed in United Kingdom Patent No. 830,816, published Mar. 23, 1960, involved the provision of a "solenoid" of one or more superconductor rings in a space craft through which a powerful current is caused to flow to induce a magnetic field, together with means to ionize the region surrounding the craft and laterally spaced electrodes between which D.C. potential is maintained to pass current through the ionized region along current paths at right angles to the desired direction of travel. The magnetic field in this instance is indicated to be stationary with respect to the field-producing conductor and thus produced by a D.C. voltage, and thrust is said to be produced by the action of the magnetic field to accelerate the ions in the current paths between the electrodes in a direction at right angles to the current paths and opposite to the desired direction of travel. However, nothing contained in this patent suggests that the "solenoid" or magnetic field generating conductive loop of the patented vehicle creates anything other than a stationary field similar to that of a conventional D.C. solenoid winding.

The present invention, instead of relying on such a system of thrust generation, involves the production of a plasma or electrically conductive field surrounding the craft, if the craft is not emersed in such an electrically conductive surrounding medium, and generation of a high intensity moving polyphase excited magnetic field about the craft produced by alternating current voltages in such a manner as to induce eddy currents in the plasma and causing the field to travel between two spaced points in a direction opposite to the desired direction of travel. Since under the Lenz's law, the current set up by an induced voltage always opposes the motion or charge in current which produced it, it follows that the currents (and thus eddy currents) set up in a conductor such as in the ionized or plasma field, located in the moving magnetic field opposes the motion of the field. The consequent motion of the conductor medium produces a reaction force to propel the craft in the desired direction. This is achieved by providing a series of electrically conductive inductive driving rings or coils spaced along a reference axis along which the craft is to be propelled. The driving rings are excited by polyphase high intensity A.C. currents generated by a suitable source within the craft and applied to the series of rings in a manner known in the art, for example in linear motor catapults, electric guns, electrohydraulic pumps for conducting liquids and the like, to produce a moving magnetic field of varying intensity wherein the point of maximum flux density travels progressively from the leading end or top of the craft to the trailing end or bottom of the craft relative to the reference axis, then switches back to the leading end and repeats the travel. If the craft is not designed solely for travel in a natural environment of highly electrically conductive medium, an air ionizer is provided at the leading end or top of the craft to highly ionize the air surrounding the craft and provide a surrounding field or cloud in which eddy currents may be induced by the magnetic field generated by the series of driving rings. Such a traveling field, when acting upon the surrounding conductive medium serving as a conductor, generates or induces eddy current therein and this induced current

flowing between finite particles of atmosphere making up the conductor coacts with the flux of the field to set up a force on the conductor tending to cause the conductor to move with the traveling field. A powerful thrust is exerted on the craft in the desired direction of travel by the oppositely directed travel of the conductor (i.e. the ionized or plasma medium). The ionizer in effect produces a hollow electrically conductive tube or annulus of highly ionized air or plasma surrounding the craft through which the craft is to travel and the rearwardly traveling primary magnetic field generated by the driving rings induces the eddy currents in this conductive tube causing the "tube" of conductive medium to be thrust rearwardly and thereby propel the craft along the tube. Stability is achieved by forming the driving rings of progressively increasing diameter progressing downwardly or toward the trailing end or bottom of the craft, and shaping the craft to direct the surrounding air and thus the ionized field or zone generally outwardly and downwardly to produce effects similar to those of dihedral in winged aircraft.

An illustrative embodiment of a craft incorporating the principles of the present invention is shown in the accompanying drawings in somewhat diagrammatic fashion, in which:

FIGURE 1 is a side elevation of a craft embodying the present invention;

FIGURE 2 is a top view thereof;

FIGURE 3 is a diagrammatic skeleton view of the primary magnetic field generating and ionizer components of the craft arranged in their relative positions to each other to illustrate the principles of operation thereof, taken along the plane 3—3 of FIGURE 2; and

FIGURES 4a and 4b are diagrammatic illustrations of the craft at vertical and tilt attitudes, respectively, with accompanying illustrations of vector forces to show the stabilizing effects of the configuration.

Referring to the drawings, the heavier-than-air craft, indicated generally by the reference character 10, comprises an air frame or fuselage 11 providing support for the various compartments of the craft and the load to be transported, having a leading end or top 12 and a trailing end or bottom 13. At an intermediate location between the top 12 and bottom 13 are a series of polyphase driving windings or coils 14, 15 and 16 spaced axially along the craft concentric with the center or reference axis 17 thereof, with the relatively trailing rings 15 and 16 located toward the trailing end 13 being of progressively greater diameter to define a generally conical arrangement diverging toward the trailing end 13. To generate a magnetic field of sufficient strength, a very heavy current must flow through a single conductor or a more moderate current through many turns. Since a single turn is more efficient, I prefer to provide a conductor in the form of a single turn closed driving ring for each of the coils 14, 15 and 16, and apply three phase A.C. voltage to the driving rings 14, 15 and 16 from a suitable source 18 with proper connections to produce a traveling magnetic field, indicated by the lines 19 in FIGURE 3, wherein the point of maximum flux density progresses from the top to the bottom of the stack of driving rings, and then switches back to the top and progresses again to the bottom. Preferably a permeable pole piece 20 extends along the center axis 17 of the craft to convert the driving rings 14, 15, 16 from an air core to a ferrite core coil system to increase the flux density. The art of connecting the polyphase supply voltage to such rings or coils is well understood as exemplified by numerous prior patents directed to linear-motor catapults, electrohydraulic pumps for electrically conductive fluids, electric projectile propelling apparatus, and the like, typical of which are U.S. patents Nos. 2,112,264 to Bowles, 2,428,570 to Jones, 2,920,571 to Fenimore et al., 3,008,418 to Blake, 3,005,116 to Reece, 3,135,879 to Baumann and 2,214,297 to Ferry.

To provide maximum magnetic field strength with minimum coil weight, the driving rings 14, 15, 16 are preferably constructed of conductive metal material maintained in a superconductive state, for example by refrigeration or cooling equipment carried by the craft.

To provide a surrounding medium in the form of a flowable mass of electrically conductive properties to serve as the "conductor" in which the traveling primary field produced by the driving rings 14, 15, 16 can induce eddy currents by mutual induction, an ionizer coil or ring 21 is supported at the top 12 of the craft supplied by a suitable high voltage source 22, to cause the surrounding air to be ionized as fast as it enters the magnetic field of the driving rings 14, 15, 16. It is recognized that as air becomes more and more highly ionized, it becomes a progressively better conductor until at a condition which supports disruptive breakdown, it is an almost perfect conductor. The ionizer 21 at the top or leading end of the craft therefore continuously ionizes the air at the leading end of the craft, providing a surrounding annulus of highly conductive medium or plasma in which the eddy currents can be induced by the driving rings 14, 15, 16. Particle repulsion as well as the repulsion of the self-induced secondary magnetic fields established by the eddy currents in the surrounding ion cloud or plasma will spread the ionized annulus to the extent of the magnetic lines of force away from the craft before they reach the level of maximum flux density as they relatively progress toward the trailing end of the craft. The movement of the driving magnetic field downwardly, as previously mentioned, set up forces on the conductor medium causing the ionized or plasma medium to travel with the driving magnetic field and thus downwardly about the craft.

Preferably, means are also provided such as the frusto-conical air-directing skirt 23 disposed just below the set of driving rings 14, 15, 16 to direct the ionized air, which moves relative to the craft toward the trailing end 13, in outwardly inclined paths at an angle relative to the reference axis 17 to more nearly shape the field of ions to fit the magnetic field produced by the similarly outwardly and downwardly inclined paths of the driving rings 14, 15, 16. This inclining of the ionized air flow paths outwardly and downwardly achieves improved stability for the craft, as will be apparent from an inspection of FIGURES 4a and 4b. With the craft 10 in the vertical attitude illustrated in FIGURE 4a, the ionized air flow as designated by the arrows 24 lies in a downwardly divergent conical path due to the effects of the air directing skirt 23. These forces or vectors all resolve into a downwardly directed vertical component 24<sub>v</sub> and a radially outwardly directed horizontal component 24<sub>h</sub>, the latter occurring in a circle so that they cancel each other and only the vertical component remains. Should the craft 10 tilt as illustrated in FIGURE 4b, the ionized air force vector 25<sub>L</sub> for the lower side of the craft is all down while the vector 25<sub>H</sub> for the higher opposite side is near horizontal, producing a couple which tends to return the craft to its proper vertical attitude. It will be appreciated that the force vectors shown represent the forces exerted on the eddy-current-conducting ionized air cloud (i.e. the conductor) by the downwardly traveling primary magnetic field produced by the driving rings 14, 15 and 16.

While the phase angle between current and voltage in electric motors is not great due to partial phase shift from inductive reactance by circuit resistance, and can tolerate the consequent efficiency loss, the use of superconductor driving rings or coils 14, 15, 16 in the craft of the present invention would substantially eliminate resistance and provide substantially pure inductance, whereby the voltage would lag the current by approximately 90° and no magnetism would result from the current in the coils. To shift the voltage back in phase with the current, capacitance is added to the circuit, preferably by capaci-

tors sufficient to provide capacitive reactance equal to the inductive reactance and thereby place the circuit in resonance with a power factor of unity. This may be accomplished by providing large condensers 26, 27, 28 in series resonant circuits with the respective driving rings 14, 15, 16.

Directional and attitude control of the craft may be effected either by control of the ionization in various radial directions or quadrants, or by distorting the shape of the magnetic field produced by the driving rings 14, 15, 16 or by other control expedients. For example, the ionizer ring 21 may, in a simple form, be a ring of spikes with alternate spikes at ground potential and a very substantial potential difference existing between the spikes so as to effect a high degree of ionization between rows of alternate spikes. The spiked ring 21 may be broken up along its circumference into a plurality of independently controllable arcuate segments, and the potential applied to the arcuate segments through a sector control 29 which moderates the applied potential to set the degree of ionization in each quadrant. By this means, the ionization can be altered to maintain constant vertical force components or lift or vary them to effect controlled tilt, while the normally zeroed out horizontal force components can be upset so that the craft has a powerful horizontal force component in the desired direction. This may be coordinated with control of total power input to the driving rings 14, 15, 16 to maintain the correct proportions of lift, tilt and forward speed for controlled flight providing control functions similar to collective pitch control in rotary wing aircraft.

Lateral directional control may also be achieved by installing a plurality of closed loop coils in the skirt of the craft below the primary coils. These directional control coils may lie in the plane of the skirt and take the form of a series of circles or regular loops which are tangent to one another around the perimeter of the craft in the skirt region. These closed loop coils would be controllable as to whether they are closed or open, for example, by remotely controlled shorting strips or conductive bridges, so that if they are closed, they form a short circuited secondary turn which, by resistance, would absorb power from the main driving coils and tend to shade the developed magnetic field at that point. If the closed circuit of this coil is broken, no current would be able to flow and no power would be absorbed. By thus decreasing the field strength in any quadrant, one would be able to tilt the craft and achieve lateral displacement.

To effect control over the amount of thrust generated, one could increase power to either the driving coils to the ionizer ring, or if desired, one may change the frequency of the phased alternating current voltages supplied to the driving coils to increase or decrease the speed of travel of the travelling magnetic field along the driving rings.

In the event the craft is to have the capability of travel in a medium or region having insufficient air or other ionizable matter, an ion source or the like would also have to be carried by the craft to provide its own source of ions or electrically conductive matter for seeding the surrounding region and producing the necessary plasma or electrically conductive annulus in which the eddy currents may be induced to provide propulsive thrust. If the craft is to travel in a fluid medium which is naturally electrically conductive, such as sea water or some other electrolyte, the medium already has the capability of conducting eddy currents and the ionizer may be dispensed with or may be used merely to improve conductivity of the naturally conductive medium.

While but one preferred example of the present invention has been particularly shown and described, it is apparent that various modifications may be made therein within the spirit and scope of the invention, and it is desired, therefore, that only such limitations be placed on

the invention as are imposed by the prior art and set forth in the appended claims.

What is claimed is:

1. A magnetohydrodynamic effects craft adapted to travel through a surrounding fluid medium wherein the zone of the medium adjacent the craft is responsive to magnetic fields to conduct mutually induced eddy currents, comprising a plurality of electrically conductive coil means capable of producing magnetic fields surrounding the craft upon conduction of electric current there-through arranged serially along an axis of the craft paralleling a desired direction of travel, means for applying polyphase alternating current electric voltages to said coil means to produce a plurality of magnetic fields fluctuating responsive to alternating currents in said coil means which are phased and magnetically superimposed to produce a collective driving magnetic field surrounding said craft whose point of maximum flux density repetitively progresses from a leading end position relative to said direction of travel to a trailing end position and switches back to said leading end position, said driving magnetic field being of sufficient strength to induce eddy currents in the adjacent zone of said fluid medium and thereby constitute the fluid medium an equivalent electrical conductor interacting with said driving magnetic field to be driven in the direction of travel of the driving magnetic field and effect propulsion of said craft in the selected direction of travel.

2. A heavier-than-air craft adapted to be propelled through a fluid medium by magnetohydrodynamic effects comprising a fuselage having a top end and a bottom end spaced along a central reference axis, means adjacent the top end of said craft for ionizing the fluid medium surrounding the craft, a plurality of inductive driving coils of electrical conductors arranged concentrically of said reference axis and located at a plurality of selected spaced positions along said axis intermediate said top and bottom ends, and means for applying polyphase alternating current voltages to said coils to produce electric currents therein having selected phase relations to each other establishing a magnetic field about each coil fluctuating about its respective coil in accordance with the alternating electric currents flowing therein, which fields are phased and magnetically superimposed to produce a collective driving magnetic field whose point of maximum flux density repetitively progresses from the top-most coil to the bottommost coil and switches back to the top-most coil, whereby said driving magnetic field induces eddy currents in the ionized surrounding medium reacting with said driving magnetic field to drive the ionized surrounding medium in the direction of travel of the driving magnetic field and propel the craft upwardly in the direction of said reference axis.

3. A heavier-than-air craft adapted to be propelled through a fluid medium capable of being ionized to a condition of high electrical conductivity by magnetohydrodynamic effects comprising a fuselage having a top end and a bottom end spaced along a central reference axis, means adjacent the top end of said craft for ionizing the fluid medium surrounding the craft to produce an ionized annulus of high electrically conductive fluid medium surrounding the craft and extending axially toward the bottom end thereof, an array of inductive driving rings formed of electrical conductors arranged concentrically of said reference axis and located at selected spaced positions along said axis intermediate said top and bottom ends, and means for applying polyphase alternating current voltages to said rings to produce electric currents therein having selected phase relations to each other establishing a magnetic field about each ring fluctuating about its respective ring in accordance with the alternating electric currents flowing therein, which fields are phased and magnetically superimposed to produce a collective driving magnetic field whose point of maximum flux density repetitively progresses from the

top to the bottom of said array and switches back to the top of the array, whereby said driving magnetic field induces eddy currents in the ionized surrounding medium reacting with said driving magnetic field to drive the ionized surrounding medium in the direction of travel of the driving magnetic field and propel the craft upwardly in the direction of said reference axis.

4. In a heavier-than-air craft as defined in claim 3, each of said driving rings being superconductor rings.

5. A heavier-than-air craft adapted to be propelled through a fluid medium by magnetohydrodynamic effects comprising a fuselage having a top end and a bottom end spaced along a central reference axis, means adjacent the top end of said craft for ionizing the fluid medium surrounding the craft, a plurality of inductive driving coils of electrical conductors arranged concentrically of said reference axis and located at a plurality of selected spaced positions along said axis intermediate said top and bottom ends, and means for applying polyphase alternating current voltages to said coils to produce electric currents therein establishing a moving driving magnetic field which repetitively progresses from the top-most coil to the bottom-most coil and switches back to the top-most coil, whereby said moving magnetic field induces eddy currents in the ionized surrounding medium reacting with said driving magnetic field to drive the ionized surrounding medium in the direction of travel of the magnetic field and propel the craft upwardly in the direction of said reference axis, said fuselage having fluid medium deflecting skirt means of generally truncated conical configuration diverging toward said bottom end between said coils and said bottom end to deflect the ionized medium surrounding the craft in outwardly and downwardly inclined paths relative to said reference axis during relative movement of the craft along said axis for developing forces upon interaction of said driving magnetic field with the ionized fluid medium tending to stabilize the attitude of the craft relative to said axis.

6. A heavier-than-air craft adapted to be propelled through a fluid medium capable of being ionized to a condition of high electrical conductivity by magnetohydrodynamic effects comprising a fuselage having a top end and a bottom end spaced along a central axis, an ionizer ring adjacent the top end of said craft, means for applying a high electrical potential to said ionizer ring for ionizing the fluid medium surrounding the craft to produce an ionized annulus of high electrically conductive fluid medium surrounding the craft and extending axially toward the bottom end thereof, an array of inductive driving rings formed of electrical conductors arranged concentrically of said reference axis and located at selected spaced positions along said axis intermediate said top and bottom ends, and means for applying polyphase alternating current voltages to said rings to produce electric currents therein having selected phase relations to each other establishing a magnetic field about each ring fluctuating about its respective ring in accordance with the alternating electric currents flowing therein, which fields are phased and magnetically superimposed to produce a collective driving magnet field whose point of maximum flux density repetitively progresses from the top to the bottom of said array and switches back to the top of the array, whereby said driving magnetic field induces eddy currents in the ionized surrounding medium reacting with said driving magnetic field to drive the ionized surrounding medium in the direction of travel of the driving magnetic field and propel the craft upwardly in the direction of said reference axis.

7. A heavier-than-air craft adapted to be propelled through a fluid medium capable of being ionized to a condition of high electrical conductivity by magnetohydrodynamic effects comprising a fuselage having a top end and a bottom end spaced along a central axis, an ionizer ring adjacent the top end of said craft, means for applying a high electrical potential to said ionizer ring for ionizing

the fluid medium surrounding the craft to produce an ionized annulus of high electrically conductive fluid medium surrounding the craft and extending axially toward the bottom end thereof, an array of inductive driving rings formed of electrical conductors arranged concentrically of said reference axis and located at selected spaced positions along said axis intermediate said top and bottom ends, and means for applying polyphase alternating current voltages to said rings to produce electric currents therein, establishing a moving driving magnetic field which repetitively progresses from the top to the bottom of said array and switches back to the top of the array, whereby said moving magnetic field induces eddy currents in the ionized surrounding medium reacting with said driving magnetic field to drive the ionized surrounding medium in the direction of travel of the magnetic field and propel the craft upwardly in the direction of said reference axis, said means for applying electrical potential to said ionizer ring including means for controlling the distribution of potential about the circumference of said ionizer ring to vary the potential at selected arcuate portions of the ionizer ring and thereby alter the ionization in various azimuthal zones surrounding the craft to guide the craft.

8. A heavier-than-air craft adapted to be propelled through a fluid medium capable of being ionized to a condition of high electrical conductivity by magnetohydrodynamic effects comprising a fuselage having a top end and a bottom end spaced along a central axis, an ionizer ring adjacent the top end of said craft, means for applying a high electrical potential to said ionizer ring for ionizing the fluid medium surrounding the craft to produce an ionized annulus of high electrically conductive fluid medium surrounding the craft and extending axially toward the bottom end thereof, an array of inductive driving rings formed of electrical conductors arranged concentrically of said reference axis and located at selected spaced positions along said axis intermediate said top and bottom ends, and means for applying polyphase alternating current voltages to said rings to produce electric currents therein, establishing a moving driving magnetic field which repetitively progresses from the top to the bottom of said array and switches back to the top of the array, whereby said moving magnetic field induces eddy currents in the ionized surrounding medium reacting with said driving magnetic field to drive the ionized surrounding medium in the direction of travel of the magnetic field and propel the craft upwardly in the direction of said reference axis, said ionizer ring comprising a plurality of electrically independent, circumferentially spaced arcuate sectors, said means for applying potential to said ionizer ring including sector control means for selectively varying the relative potential applied to said sectors to vary the ionization of the surrounding fluid medium in selected radial directions relative to the reference axis to guide the craft in selected directions.

9. A heavier-than-air craft adapted to be propelled through a fluid medium capable of being ionized to a condition of high electrical conductivity by magnetohydrodynamic effects comprising a fuselage having a top end and a bottom end spaced along a central reference axis, means adjacent the top end of said craft by ionizing the fluid medium surrounding the craft to produce an ionized annulus of high electrically conductive fluid medium surrounding the craft and extending axially toward the bottom end thereof, an array of inductive driving rings formed of electrical conductors arranged concentrically of said reference axis and located at selected spaced positions along said axis intermediate said top and bottom ends, the successive individual driving rings being of progressively increasing diameter progressing from the top end to the bottom end of said craft, and means for applying polyphase alternating current voltages to said rings to produce electric currents therein having selected phase relations to each other establishing a magnetic field about each ring fluctuating about its respective ring in

9

accordance with the alternating electric currents flowing therein, which fields are phased and magnetically superimposed to produce a collective driving magnetic field whose point of maximum flux density repetitively progresses from the top to the bottom of said array and switches back to the top of the array, whereby said driving magnetic field induces eddy currents in the ionized surrounding medium reacting with said driving magnetic field to drive the ionized surrounding medium in the direction of travel of the driving magnetic field and propel the craft upwardly in the direction of said reference axis.

5

10

10

## References Cited

## UNITED STATES PATENTS

3,071,705	1/1963	Coleman et al. -----	60—35.5 X
3,138,019	6/1964	Fonda-Bonardi -----	60—35.5 X
3,150,483	9/1964	Mayfield et al. -----	60—35.5
3,174,278	3/1965	Barger et al. -----	60—35.5

## FOREIGN PATENTS

830,816	3/1960	Great Britain.
---------	--------	----------------

FERGUS S. MIDDLETON, *Primary Examiner.*